

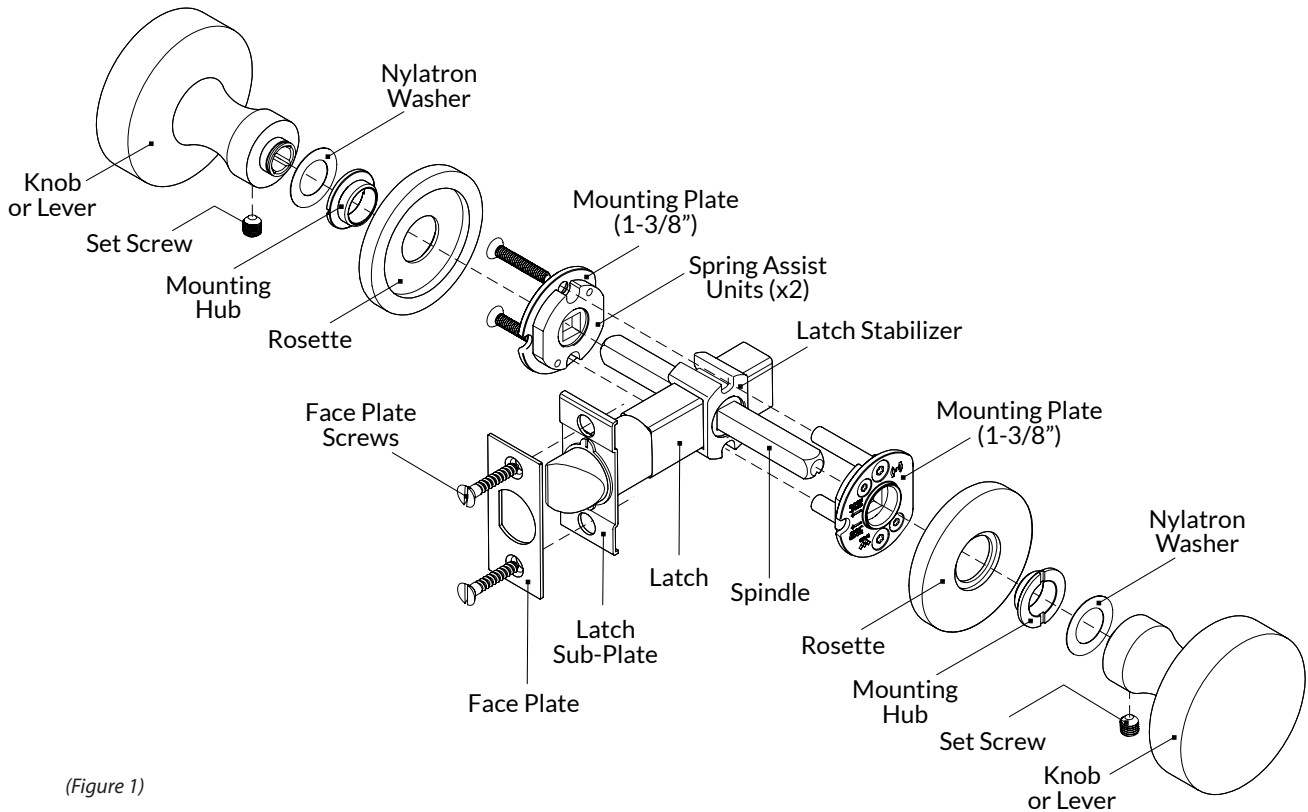

WATER STREET

JAMESTOWN NEW YORK

TS-PS / TS-PU - TUBULAR SECTIONAL PASSAGE OR PRIVACY PIN SET INSTALLATION - 1-3/8" BORED DOORS



(Figure 1)

PREPARE DOOR & INSERT LATCH

1. If the door is not pre-drilled, prepare the door per the template provided with a 1-3/8" bore. Confirm your backset before drilling.
2. Install the latch sub-plate onto the latch. Rotate the latch bolt to the desired direction based on handing, then insert the assembly into the door. (Figure 2)
3. Install the latch face plate and secure with the face plate screws.
4. From the **right hand side of the door**, attach the plastic latch stabilizer onto the latch body.
5. Slide spindle through the latch, centering in the door. The set screw slots should be on the bottom, facing the floor. (Figure 3)

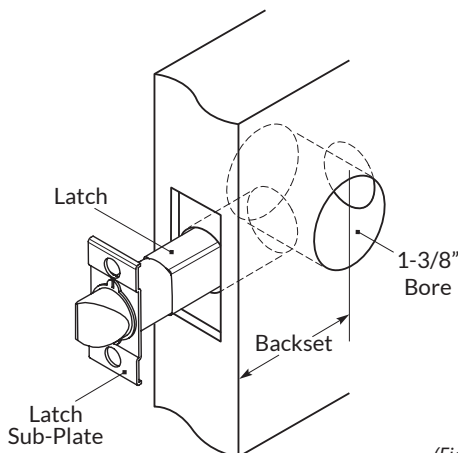

(Figure 2)

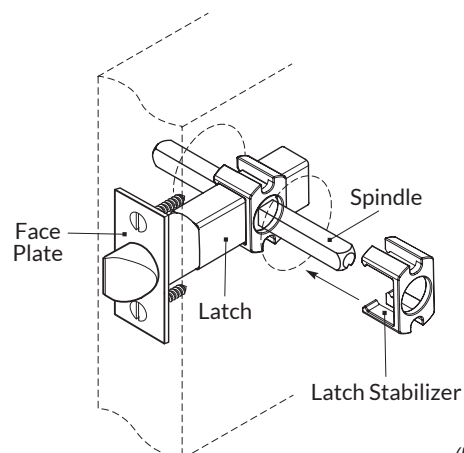

(Figure 3)



WATER STREET
JAMESTOWN NEW YORK

TS-PS / TS-PU - TUBULAR SECTIONAL PASSAGE OR PRIVACY PIN SET INSTALLATION - 1-3/8" BORED DOORS

ROSETTE MOUNTING ASSEMBLY

6. Again working from the **right hand side of the door**, fit the spring assist unit of the mounting plate onto the spindle, then slide the mounting studs through the latch stabilizer.
7. Fit the second mounting plate onto the spindle and snug both plates to the door surface. Make sure the spindle remains centered in the door. Install the two #8 machine screws into the mounting studs and tighten evenly. (Figure 4)

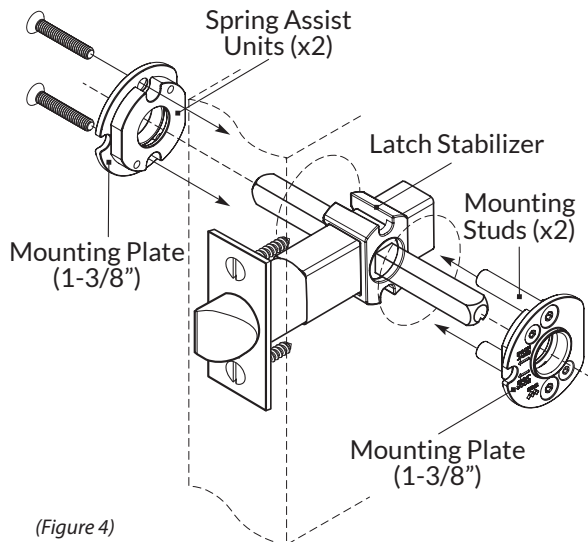

(Figure 4)

8. Test the function of the latch. If binding occurs, loosen the face plate screws slightly until the latch functions smoothly.

INSTALL ROSETTES

9. Position a rosette over the mounting plate. Insert the mounting hub and tighten into the mounting plates with the rosette installation tool. Repeat on the other side of the door.

If your set uses a privacy pin, make sure the privacy access holes in the rosettes are properly located over the privacy latch activator. Screw the privacy pin into the interior side of the latch. (Figure 5)

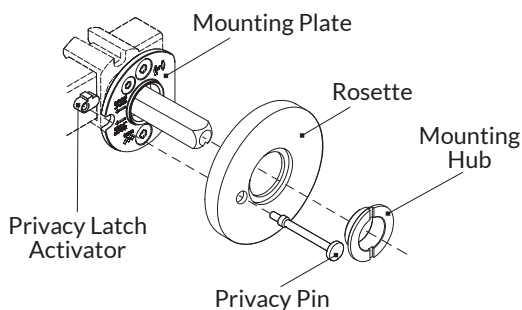

(Figure 5)

INSTALL KNOBS OR LEVERS

10. Place nylatron washers over the spindle and mounting hubs. With the set screw facing the floor, slide both knobs or levers onto the spindle. Snug them up to the rosettes.
11. Secure the knobs or levers to the spindle by firmly tightening the set screws with an Allen Wrench. (Figure 6)

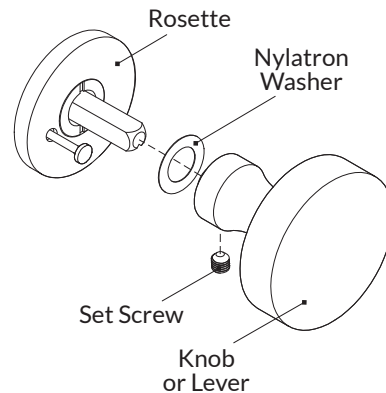

(Figure 6)

DOOR JAMB

12. Measure the jamb to determine the location the latch bolt strikes when the door is fully closed. Using the strike plate template provided, prepare the door jamb to accept the dust box and strike plate.

Note: Determine if the latch strike plate is a full lip or T-strike, and the handing required. Mortise the jamb accordingly.

13. Install the dust box and face plate with the screws provided. Make sure the face plate sits flush with the jamb surface; deepen the cavity as needed. After installation, if the latch does not fully engage with the strike, loosen the screws and adjust. (Figure 7)

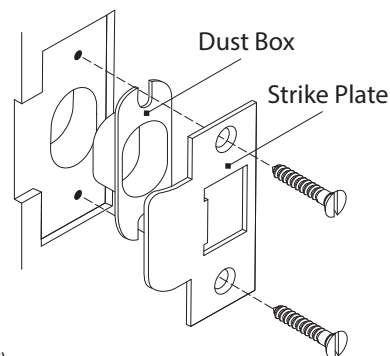

(Figure 7)



WATER STREET

TS-PU Tubular Push Pin Privacy
Door Prep 1-3/8" Bore

TS-PS Tubular Passage
Door Prep 1-3/8" Bore

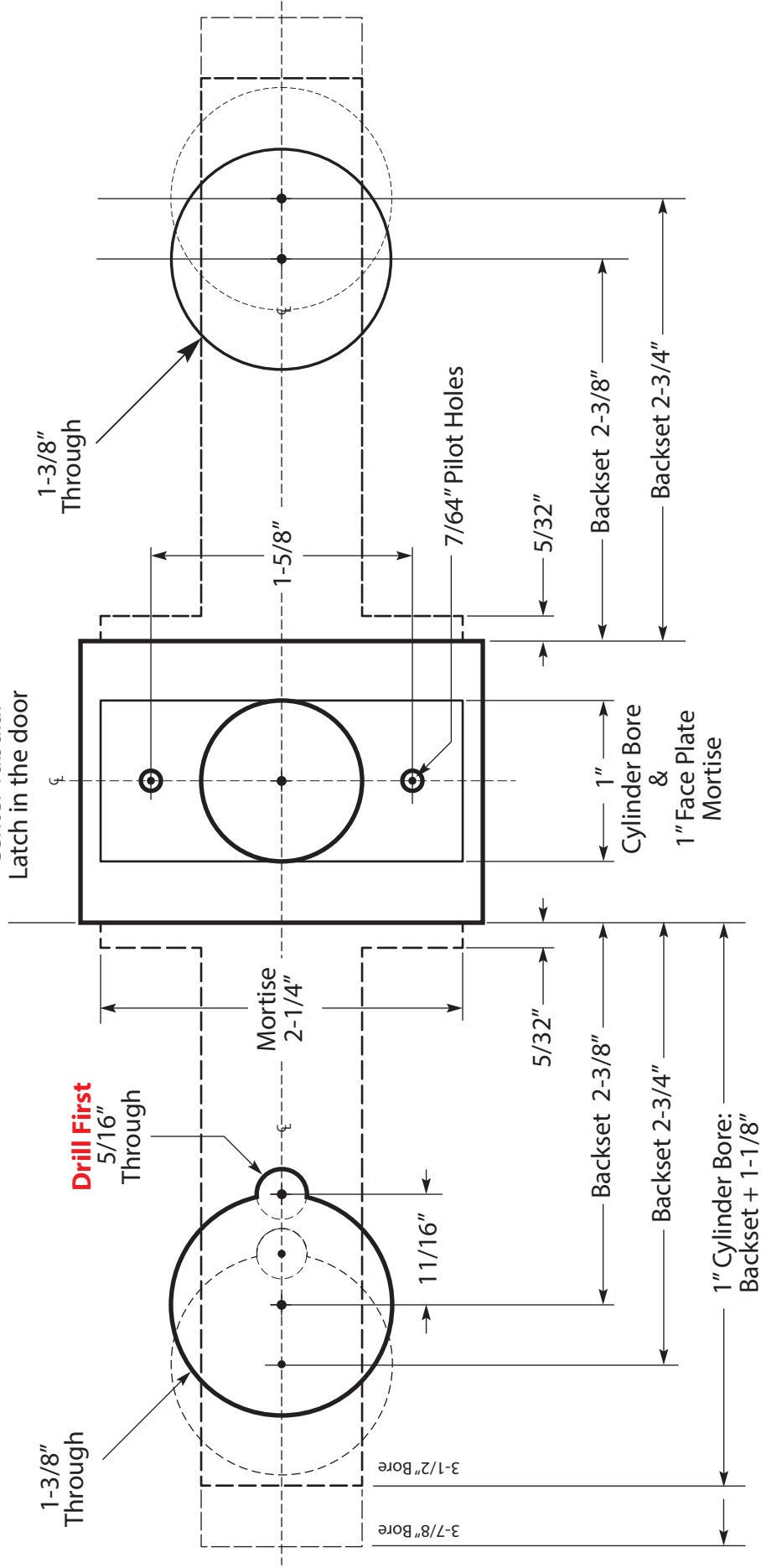

Proprietary And Confidential

© WSB Hardware, Inc. 2022

Any reproduction in part or as a whole without the written permission of Water Street Brass is prohibited.

WS40322 Tubular
Passage & Privacy
Latch 1-3/8" Bore



WATER STREET

T-Lip Strike

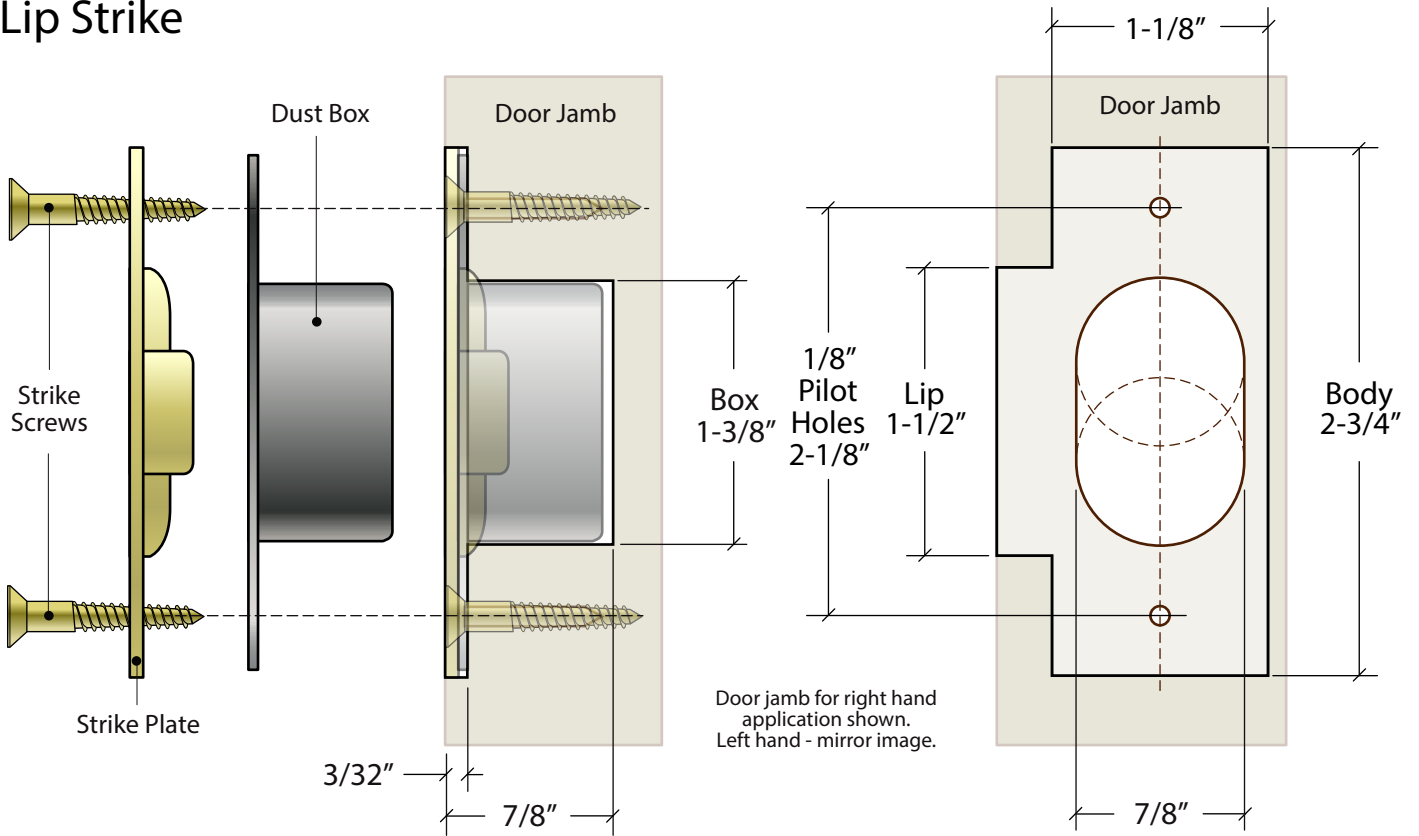

Full Lip Strike

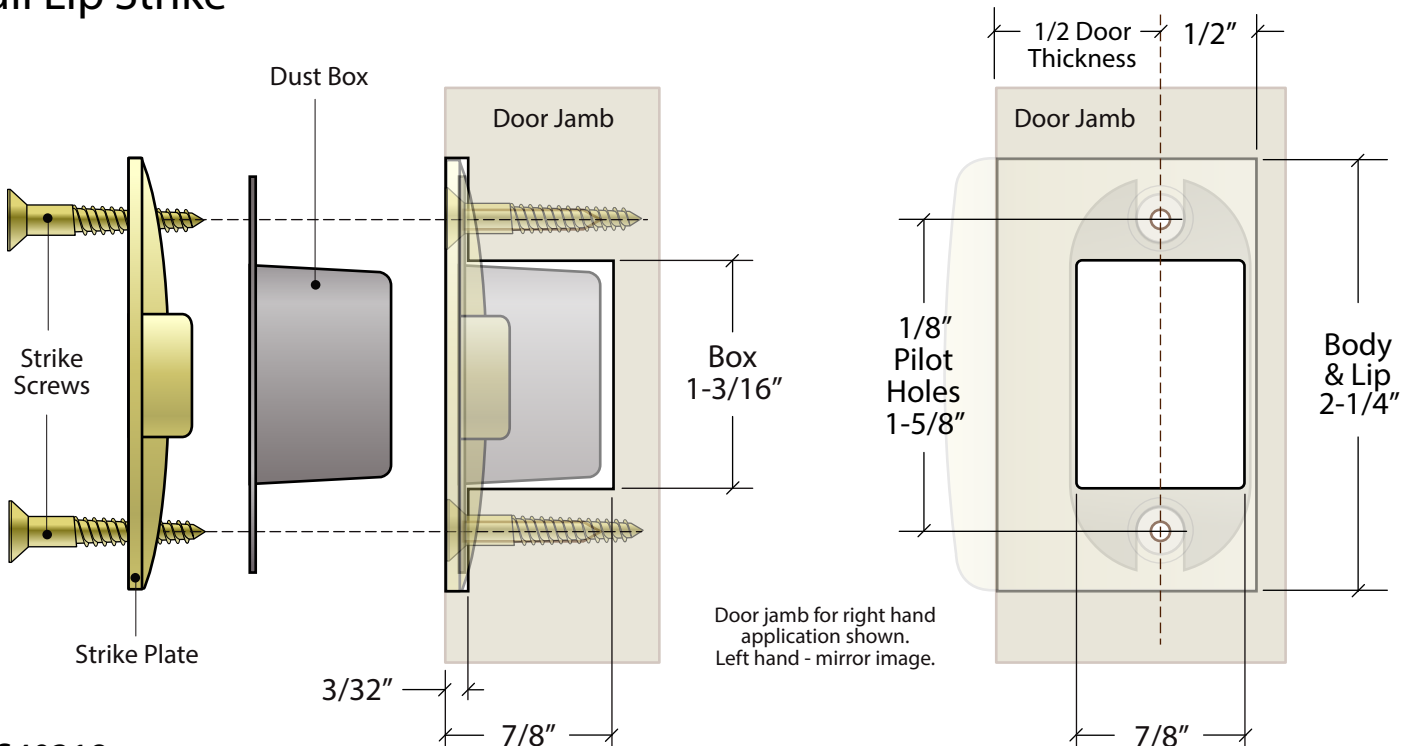

WS40318
Tubular Strike Templates

Proprietary And Confidential
© WSB Hardware, Inc. 2022