



WATER STREET  
BRASS

## Privacy Escutcheon Set Tubular Latch x Mortise Bolt Installation

### PREPARE THE DOOR

1. Establish the desired latch height on your door. Using the provided templates for your lock or latch, mark hole locations on the door.

It is a good idea to lightly pencil a backset line on the interior side of the door, parallel to the door edge. Your spindle, thumb turn and through bolt holes will all fall on this line.

2. Using the drill & bore sizes specified on the template, carefully drill the door. On the door edge, mark and drill two pilot holes for the installation screws.

### INSTALL THE LATCH

3. Install the latch body and face plate into the door and secure loosely with the screws provided. Do not tighten completely at this time. You will need to check alignment and function after the mortise bolt has been installed.

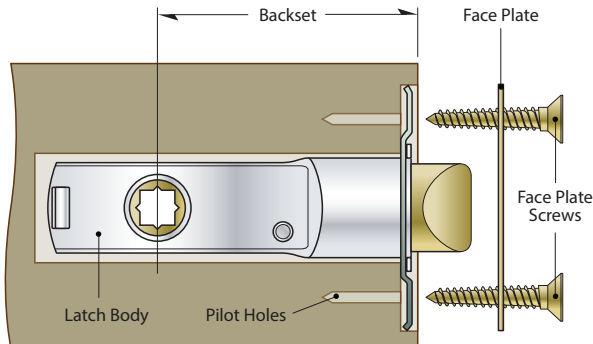

### INSTALL THE MORTISE BOLT

4. In the same manner as the latch, install the mortise bolt and face plate into the door and secure with the screws available.

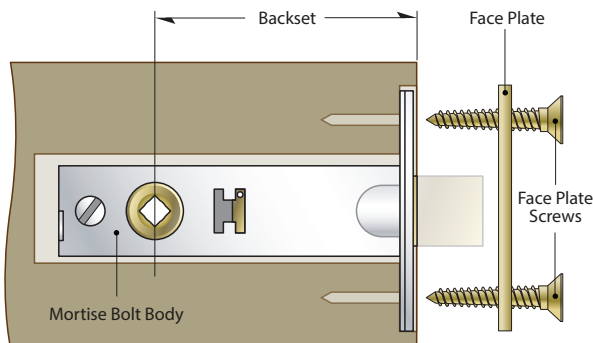

### CHECK ALIGNMENT AND FUNCTION

5. Begin by inserting the spindle into the latch body. You will begin with the interior plate assembly, which should have the knob/lever and thumb turn attached.

Make sure the spindle is centered in the latch body. **To prevent binding, we recommend the grooves in the spindle be facing up, away from the set screws.**

While holding the spindle in place, slide the interior plate assembly onto spindle. The thumb turn stem should fit into the mortise bolt body.

**NOTE:** The thumb turn stem is designed to fit doors in excess of 4" thick. Measure and cut this stem so that it reaches to the approximate center of the mortise bolt body.

You may want to tighten the interior knob/lever set screw at this time.

#### (THROUGH BOLT LOCATIONS)

If your plates are using through bolts instead of surface mount screws, you will need to mark the location for the screws and drill two 9/32" holes in the door. Use the screw holes in the interior plate to determine the location. These holes will be centered on the backset line.

6. Carefully slide the exterior plate assembly onto the exterior side of the door. With both plates in place, you can now test that the latch does not bind and that the mortise bolt functions with the thumb turn.

Once satisfied that the alignment is proper, you can now tighten the face plate screws on the latch and mortise bolt.

### ATTACH THE PLATES TO THE DOOR

7. If the plates are surface mounted, mark the screw hole locations. Punch and drill pilot holes for all the surface mount screws and carefully install the screws.

If through bolted, carefully tighten the through bolts until the plates sit firmly in place.

**NOTE:** Never use power tools to tighten the through bolts! Too much torque will strip the mounting attachments from the exterior plate!

Using the Allen Wrench provided, tighten the set screws on the knobs/levers firmly.



# WATER STREET BRASS

## DOOR JAMB

8. Carefully measure the jamb to determine the exact location that the latch strike and lock bolt land when the door is fully closed. Mark the locations. Using the strike plate as a template, outline the shape and begin to mortise the door jamb to accept the strike.

Mortise the dust box cavity as shown here. If using a full lip strike, the dust box will be smaller; measure carefully and install.

After installation, if the latch does not fully engage with the strike, loosen the screws and adjust slightly.

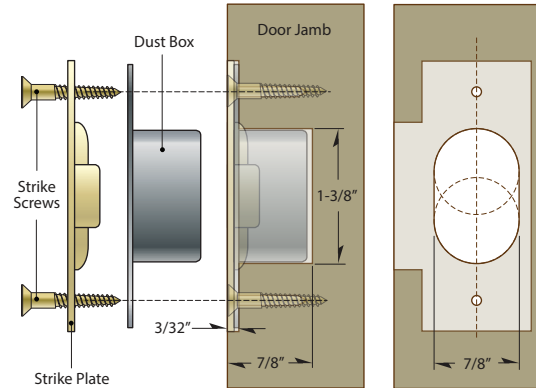

**\*Note:** The mortise bolt may be located above or below latch.

The spacing may vary from the template so confirm the latch placement and all measurements before preparing the door.

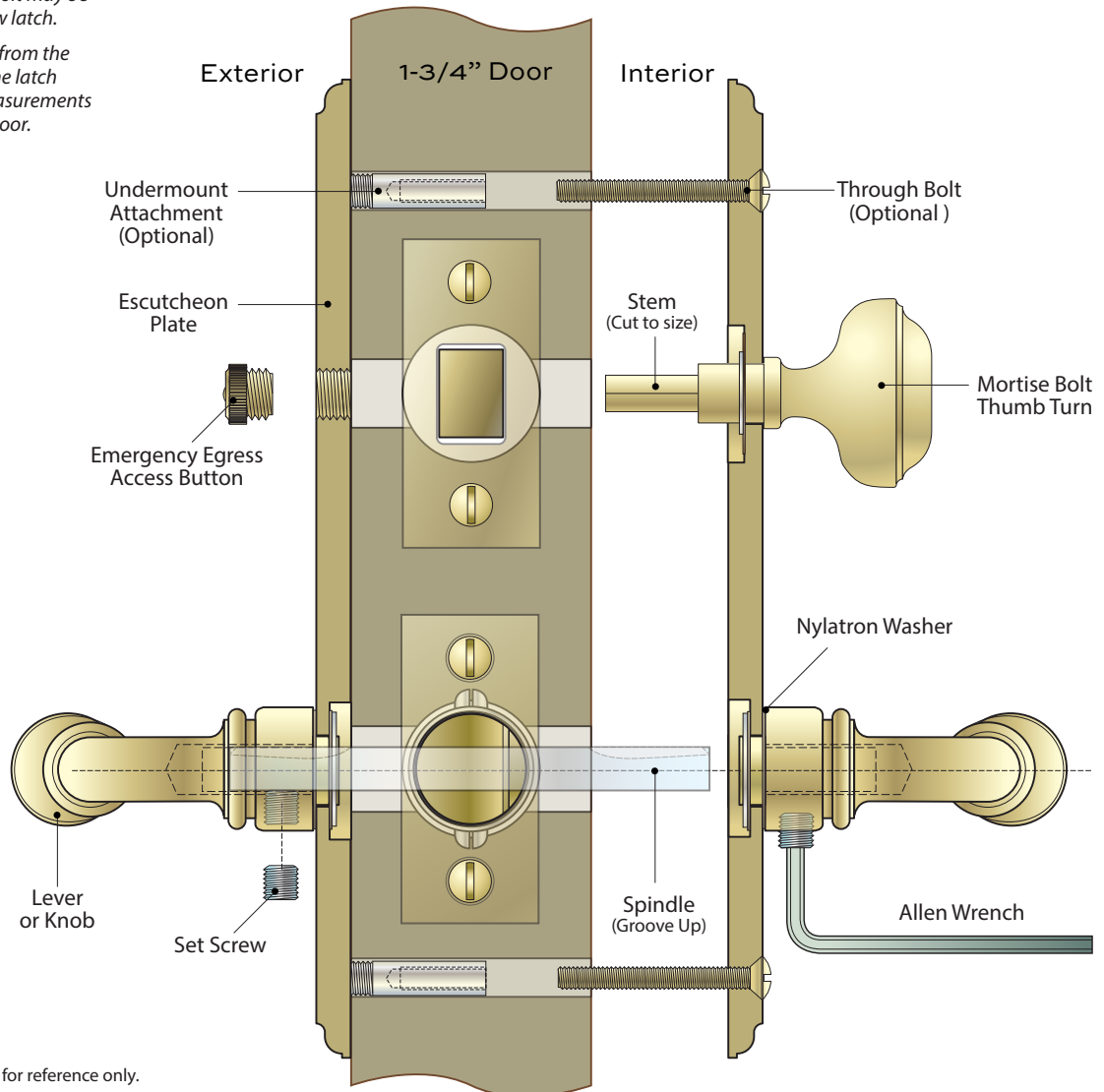

Illustrations not to scale; for reference only.