



WATER STREET
BRASS

Mortise Privacy Set Installation Instructions

These instructions are for the installation a mortise lock privacy set. The hardware will work with either door knobs or levers, depending on the lock specified. From this point forward, we'll just refer to levers.

PREPARE THE DOOR

1. If your door has not already been prepared for your lock installation, do so by using the templates provided for your specific lock model. Be sure to confirm the proper backset, function and handing for your door prior to any drilling or mortising.
2. If your plates are using through bolts, use the provided template to mark and drill the door for the bolts. If using surface mount screws, you will position the plates as installing and mark the screw positions.
3. Install the mortise lock body in the door using the screws provided. Do not install the lock body face plate at this time.

INSTALL THE HARDWARE

4. Insert the spindle into the lock body and center it. The security notches should be on the exterior side of the door and the set screw grooves should be at the bottom, facing the floor.

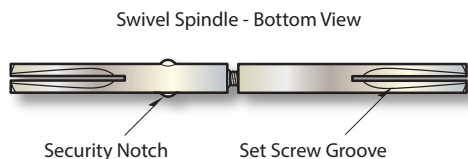

5. First position the exterior plate on the door by holding the spindle in place and sliding the lever/plate assembly into position. Tighten the set screw in the lever to keep the spindle centered.

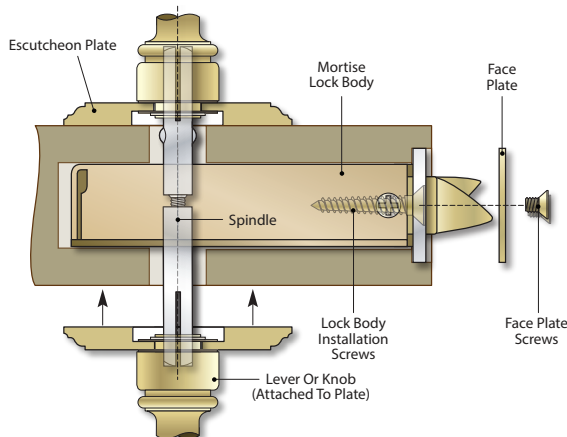

Next align the interior plate so the spindle engages the lever and the thumb turn stem slides into place in the lock body. The thumb turn stem should fully engage with the lock, but should be cut to extend midway through the lock body. Adjust the plates to sit square with the door edges.

Loosely install the through bolts as shown in the assembly illustration. Do not tighten these screws yet.

6. Adjust the spindle position if needed, then firmly tighten the interior lever or knob set screw.
7. Test the function of the levers and the thumb turn. When satisfied that all are working properly, firmly tighten the through bolting to hold the plates in place.

NOTE: Do not use power tools to tighten these screws! Hand tighten the through bolts only.

8. Complete installation by attaching the mortise lock face plate.

DOOR JAMB

9. Carefully measure the jamb to determine the exact location that the lock bolt will land when the door is fully closed. Mark the location. Using the strike plate as a template, outline the shape and begin to mortise the door jamb 1/8" deep to accept the strike and lip.

Finally, measure the dust box and mortise the jamb to the proper depth and width.

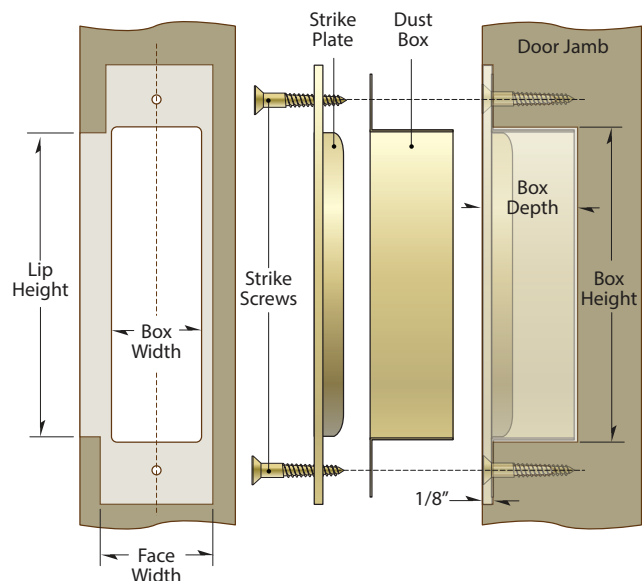



WATER STREET BRASS

ASSEMBLY CROSS SECTION

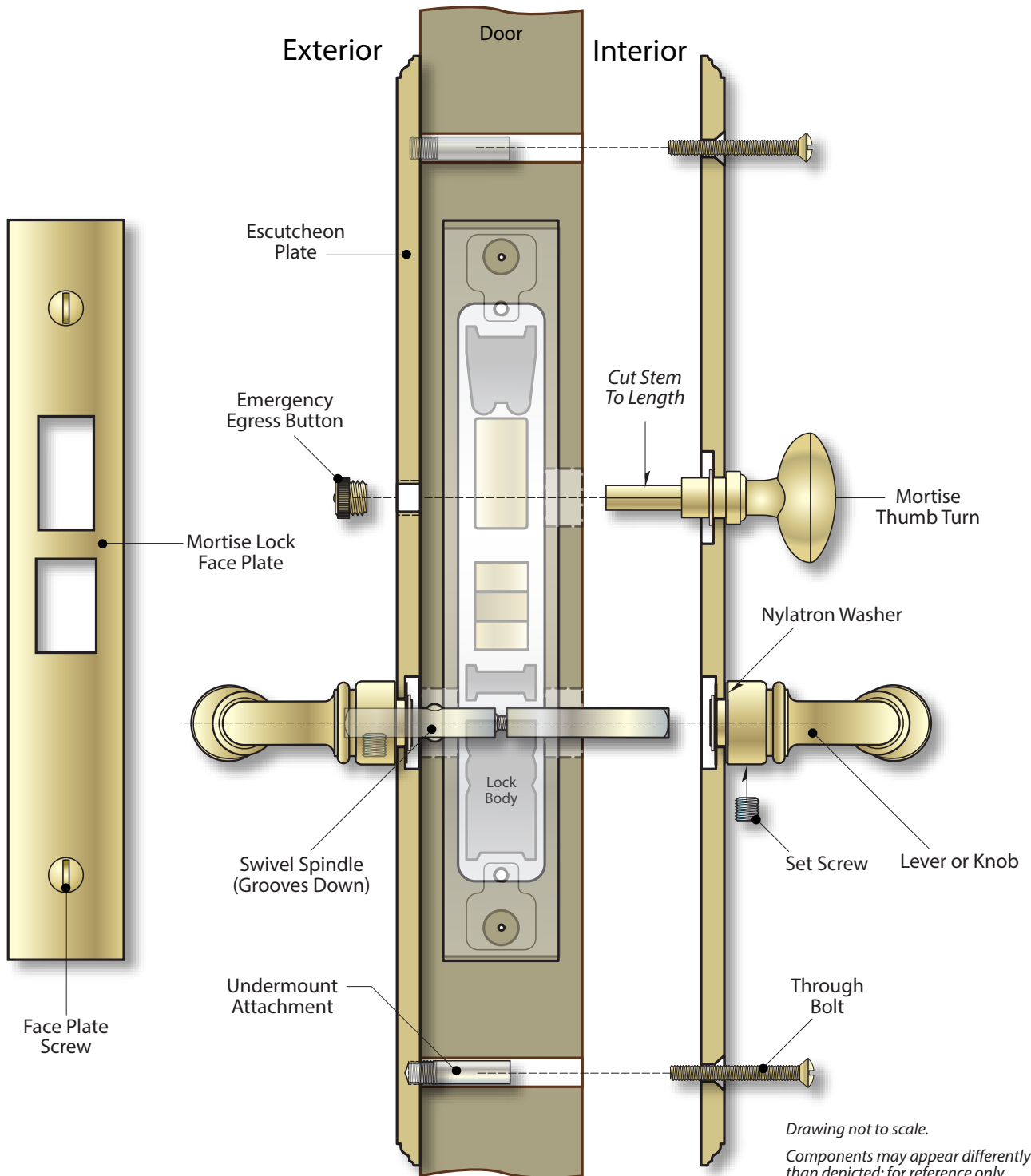

*Drawing not to scale.
Components may appear differently
than depicted; for reference only.*