



WATER STREET
BRASS

Dummy Installation Sectional Trim

PREPARE THE DOOR

1. Establish the desired knob or lever height on your door. Measure the proper backset as indicated on the template and mark the center location.

For dummy applications, it is usually desirable to match the height and backset of any active doors in the vicinity of the dummy door. However, thin door stiles or other factors may make this impractical.

2. Using the drill & bore sizes specified on the template, carefully drill the door to accept the half dummy rosette mounting plate.

INSTALL THE HARDWARE

3. Insert the half dummy rosette mounting plate in the bore in the door. Using a carpenter's square, position the plate as shown. This will assure that the spindle in the plate is square to the edge of the door. Mark the screw hole locations and drill 3/32" diameter pilot holes for the mounting screws. For metal doors, these holes should be drilled and tapped for #6-32 screws.

4. Attach the mounting plate to the door using the three screws provided.

5. Locate the rosette over the mounting plate and secure with the threaded hub. Tighten this hub using the rose mounting tool provided, taking care not to scratch or mar the rosette surface.

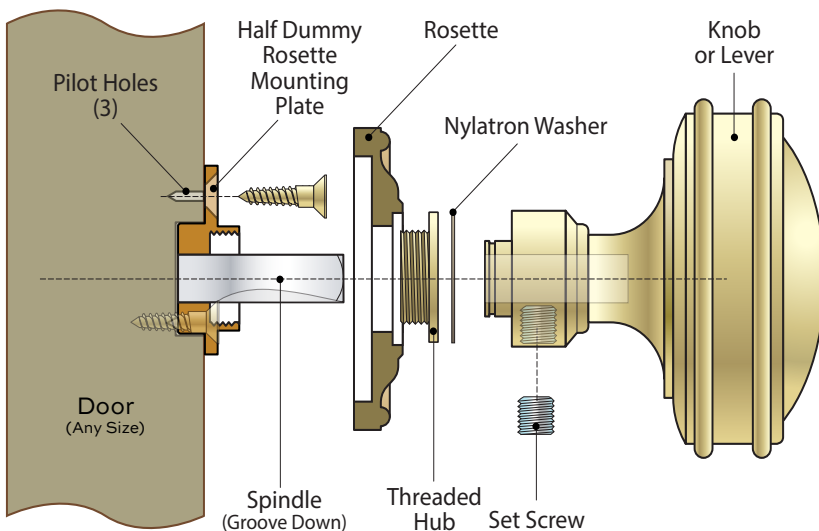
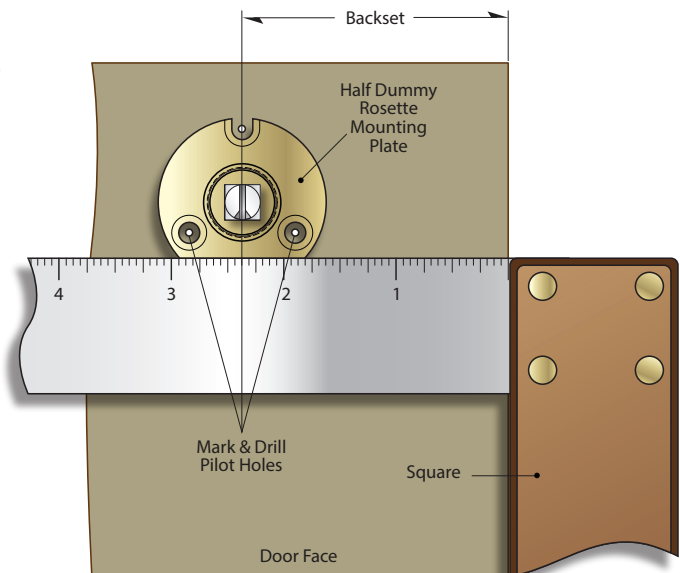

6. Slide the knob or lever over the spindle and press until it seats firmly against the rosette. The nylatron washer is not required for this application, but may minimize any gapping between the knob or lever and the rosette.

7. Tighten the set screw with the hex wrench provided. This screw should seat within the spindle groove and when fully installed, little or no play should be felt when using the knob or lever.